

1-800-214-7716
www.midwestair.com

M A P C O
MIDWEST AIR PRODUCTS CO., INC.

Pollution Solutions

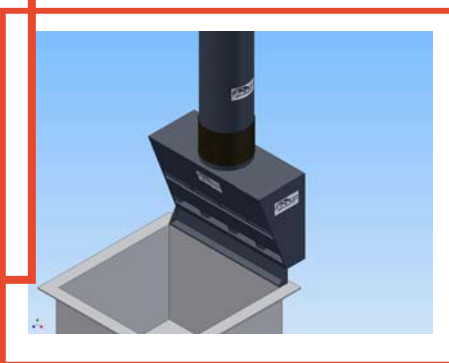

- wet scrubbers
- composite mesh pad (CMP) mist eliminators
- exhaust fans
- exhaust hoods
- canopy hoods
- corrosion-resistant duct systems
- nation-wide installations
- maintenance programs
- custom fabrications
- design services



PO Box 5319
281 Hughes Drive
Traverse City, MI 49686

Ph: 231-941-5865
Fax: 231-941-1636

Fume Scrubbers—MW-100, 200, 300, Enforcer III™ and Ultra-MACT™

Mapco offers a complete line of quality built, corrosion-resistant horizontal and vertical fume scrubbers.

MAPCO FUME SCRUBBERS

Mapco fume scrubber design is based on wetted, packed bed technology to achieve removal of water soluble contaminants, soluble gas and particulate matter through Mass Transfer (gas absorption) and Impingement (mechanical separation).

STANDARD FEATURES

- Corrosion resistant PVC
- 3/4" thick flanges and external reinforcing
- 3/8" thick scrubber shell
- Stainless steel hardware
- Vertical sealless CPVC recirculation pumps
- Easily removable spray headers
- Removable packing
- Leak resistant heavy duty bolt on-doors
- Hydrostatically tested at the factory
- Full-cone spray nozzles
- Chevron and mesh pad mist eliminators
- Integral coated steel base

TYPICAL APPLICATIONS

- Anodizing
- Chrome Plating
- Bright Dip
- Battery Manufacturing
- Pharmaceutical
- Metal Finishing
- Bright Dip
- Cleaning
- Lab Exhaust
- Descaling
- Stripping
- Etching
- Chemical Processing
- Electroless Nickel
- Chemical Machining
- Photo Chemical Machining
- Semi-Conductor Chemistries
- Steel Pickling
- Gravure Printing
- Aerospace
- Nox Systems

MW-300



Ultra-MACT™



MW-200



MW-100



Enforcer III (CMP) Mist Eliminator

Corrosion Resistant Single Width Exhaust Fans—BI, GP and GI

Class I, II, III Construction
Capacities to 70,000 CFM

Corrosion Resistant Construction
PVC, FRP, Polypropylene & S.S.

- Heavy-gauge welded PVC, Poly Pro, FRP or Stainless Steel construction with steel base
- Continuous welded housings provide the strongest possible construction
- Fan wheels are statically and dynamically balanced at the specified running speed after final assembly
- Heavy duty bearings are selected for long service life through the entire operating range of the fan
- Capacities to 70,000 CFM
- 15 sizes: 12" through 66" wheel diameters
- Available in clockwise and counterclockwise rotations in any six standard discharge positions
- Unique thermally formed inlet cone with airflow diverter improves fan efficiency.



GP Fan

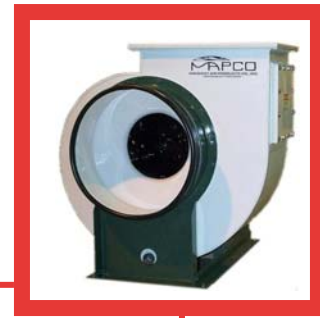

BI Fan

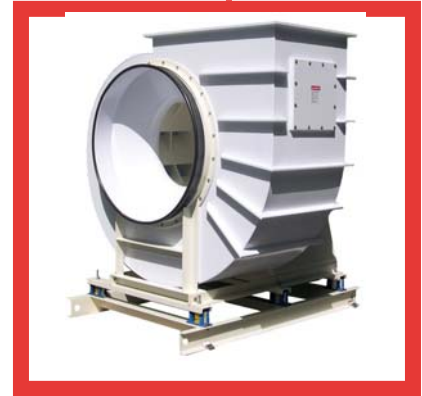

BI Centrifugal Exhaust Fan

Composite Mesh Pad (CMP)

Mist Master™ In-Line Mist Eliminators
Terminator™ Exhaust Hood
Horizontal MW- 400

- Hard Chrome
- Decorative Chrome
- Chrome Anodize
- Water Mist
- Phosphoric Acid
- Nitric Acid
- Sulfuric Acid
- Caustic Etch
- Caustic Cleaners
- Plating Solution Mist
- Cyanide Solutions
- Chemical Etchants
- Metal Plating Solutions

Mapco Mesh Pad Mist Eliminators have been tested under actual operating conditions to an efficiency of 99.94% for removal of Hexavalent Chrome. Mesh pad mist eliminators will not remove gases or gaseous odors.



Mist Master™ Vertical Mist Eliminator



Fume Arrestor™



Mist Master™ Horizontal Mist Eliminator

Highest Value
Exhaust and Pollution
Control Equipment

“and the
beat
goes
on”

Corrosion Resistant PVC Duct
Corzan™ CPVC Duct
Fiberglass Overlay



Turn-key
Installations



Corzan™
Duct



Motorized Dampers



Terminator™
Composite Mesh Pad
Exhaust Hoods

