

INSTALLATION OPERATION MAINTENANCE

**DO NOT STORE GRAY PVC MIST
ELIMINATORS IN DIRECT SUNLIGHT**

- MistMaster™ In-Line Mist Eliminators
- Terminator™ Exhaust Hood
- Horizontal MW-400



**Vertical In-Line
Mist Eliminator**

Built to Last



**Horizontal In-Line
Mist Eliminator**

PO Box 5319
281 Hughes Drive
Traverse City, MI 49686

Ph:231-941-5865
Fax: 231-941-1636
mapco@midwestair.com

JOB NO: _____

CUSTOMER: _____

APPLICATION: _____

INDEX

Caution Notes	3
Washdown Schedule	4
Introduction	6
Safety	
Receiving and Inspection	
Handling and Storage	
Duct Connections	
Operating Temperatures	
Materials of Construction	
Installation Instructions	7
Drain and Supply Piping	
Washdown Notes	
Spray Nozzles	8
Mesh Pads Filter Media	
Trouble Shooting	9
Mist-Master™ Parts Drawing	10
Terminator™ Exhaust Hood Parts Drawing	11
MW-400 Parts Drawing	12

CAUTION

Responsible Personnel must be assigned to the installation, operation and maintenance of this unit. Read complete manual prior to operating this unit. **DO NOT WASH FINAL STAGE WITH FAN RUNNING**. Observe fan discharge stack immediately after start-up and also on a regular basis thereafter. If excessive misting is present, shut down system immediately and notify MAPCO. Serious damage could occur to property if unit is run under this condition.

Before putting mist eliminator into operation:

1. Check all mesh pads for separation between hood side wall and/or mesh pad retainer. Also check mesh pad for voids. Any opening or gap in mesh pad could allow mists to bypass mesh pads.
2. Plumbing: Make sure all plumbing is installed to code. Check for leaks.
3. **Velocity/CFM:** External static pressure for the proposed system may vary depending on actual field conditions. Make sure exhaust fan is exhausting proper volume (**CFM**). Deviation from design could cause excessive misting at the mist eliminator.
4. **Spray Pattern:** Check spray nozzles upon start-up for good spray pattern. Debris lodged in filter media could become dislodged during transit. Without a filtering device, debris could become lodged in spray nozzle causing little or no flow.

Any malfunction of the mist eliminator should be reported to MAPCO immediately for repair or service instructions.

Start-Up Service:

In addition to this installation, operation and maintenance manual, MAPCO offers a factory trained service representative to perform, assist or advise in the installation and start-up of this equipment. The cost for this service is charged per man at the following rates:

- | | |
|---|--------------|
| A. First eight (8) hours of a single day | \$50.00/hour |
| B. Overtime hours in a single day | \$65.00/hour |
| C. Sunday or Holiday | \$80.00/hour |
| D. Other expenses such as airfare, hotel, car rental, meals, parts, tax, freight, etc. if applicable will be charged at cost plus 15% administration fee. | |
| E. Company Vehicles | |
| 1. Company car or truck @ \$.50/mile | |
| 2. Company truck and trailer @ \$1.50/mile | |

Note: MAPCO assumes the "End User" is knowledgeable of this equipment and fully understands the risks associated with the installation, operation and maintenance of the equipment purchased.

WASHDOWN SCHEDULE 24 HR DAY

MW-400 MIST ELIMINATOR WASHDOWN SCHEDULE

PHASE	DELIVERY GPM	FREQUENCY	DURATION (SECONDS)	GALLONS (PER CYCLE)	GALLONS (PER DAY)	RINSE TYPE
Stage I						
Stage II						

NOTES:

MistMaster™ INLINE MIST ELIMINATOR WASHDOWN SCHEDULE

PHASE	DELIVERY GPM	FREQUENCY	DURATION (SECONDS)	GALLONS (PER CYCLE)	GALLONS (PER DAY)	RINSE TYPE
Stage I						
Stage II						

NOTES:

Terminator™ Exhaust Hood WASHDOWN SCHEDULE

PHASE	DELIVERY GPM	FREQUENCY	DURATION (SECONDS)	GALLONS (PER CYCLE)	GALLONS (PER DAY)	RINSE TYPE
Stage I	5.3 gpm	4 to 6 hrs	30 to 60	2.65 to 5.3	10.6	Fresh D.I.
Stage II						

NOTES:

- Mist Eliminator washdowns will be initiated by programmable timer, plating machine cycle, independent PLC and/or plating tank level control.
- The washdown schedule suggested above is a recommended starting point only. Should concentrated chemical accumulate inside the equipment, or effluent from periodic washdowns not run clean or nearly clean at the end of the washdown cycle, a need for more frequent or longer duration washdowns will be required.

Continued operation of mist eliminator with inadequate washdowns may result in damage to the mist eliminator and a concentrated discharge at the exhaust stack.

INITIAL WASHDOWN PROGRAM FORM

START-UP DATE: _____ CUSTOMER: _____ JOB NO: _____

TIME	CHANNEL 1 STAGE I	CHANNEL 2 STAGE II	CHANNEL 3	CHANNEL 4
5:30 AM				
6:00 AM				
6:30 AM				
7:00 AM				
7:30 AM				
8:00 AM				
8:30 AM				
9:00 AM				
9:30 AM				
10:00 AM				
10:30 AM				
11:00 AM				
11:30 AM				
12:00 PM				
12:30 PM				
1:00 PM				
1:30 PM				
2:00 PM				
2:30 PM				
3:00 PM				
3:30 PM				
4:00 PM				
4:30 PM				
5:00 PM				
5:30 PM				
6:00 PM				
6:30 PM				

Programmed washdowns to occur between 6:00 AM and 5:30 PM

INTRODUCTION—The performance of every Mist Eliminator depends on many factors. The purpose of this manual is to make you aware of these factors so you will obtain the utmost efficient and dependable performance.

Providing that proper care is exercised in installing this equipment, and if it is given reasonable maintenance, you can be assured of trouble free operation.

It is important that you study this manual prior to installing this equipment to assure safe installation and operation.

SAFETY - The very nature of air handling equipment and accessories present a hazard to personnel during installation and maintenance. The following precautions should be observed prior to installing, starting or maintaining this equipment.

1. Inspect the name plates or other tags for special instructions.
2. It is recommended that this equipment be installed by personnel familiar with the installation of this type of equipment.
3. All motors should be locked out until installation is complete. This is accomplished by padlocking the disconnect switch in the off position. Inspect the hood interior for debris or loose parts.
4. Inspect ductwork for leakage of harmful or corrosive fumes.
5. Never discharge corrosive or harmful fumes from the fan. The mist eliminator should always be operated with the proper amount of water. Follow good safety practices when installing or maintaining this equipment.



RECEIVING AND INSPECTION - Upon receipt of shipment, check first to see that all items on bill of lading and/or packing slip have been received. By careful inspection determine whether damage has occurred in transit. Any shortage or damage should be noted and a claim should be filed immediately.

Equipment manufactured by Midwest Air Products Co., Inc. has been inspected at our factory in Traverse City, MI.

HANDLING AND STORAGE - If installation of the equipment is delayed and storage is made outdoors, provide reasonable weather protection. When transporting or installing this equipment exercise care to avoid breakage of PVC. Never pick this equipment up by the flanges.

DUCT CONNECTIONS - Duct loads can cause distortion with consequent damage. Support ductwork independently of the mist eliminator.

OPERATING TEMPERATURES - The mist eliminator is fabricated from PVC. When constant temperature exceeds 130° F the unit will distort causing severe damage.

MATERIALS OF CONSTRUCTION - The mist eliminator body is typically fabricated from 1/8", 3/16", 1/4" and 3/8" Type I, Grade I corrosion resistant, unplasticized PVC. Access doors and removal doors are 3/8" thick PVC.

It is recommended that all chrome control equipment be set up with some form of secondary containment should a leak occur.

INSTALLATION INSTRUCTIONS

1. Prior to installation, inspect mesh pads for damage during transit. This is accomplished by looking through the inspection door, hood outlet or inlet/outlet with the aid of a flashlight. If media is separated from sidewall, consult factory immediately.
2. Inspect all plumbing connections for breakage or leaks.
3. If flanges are not drilled, the bolt holes should be drilled on 4" to 6" centerlines. Use either 1/4" or 3/8" bolts with a flat washer under both bolt head and nut. It is important that a caulking or gasket material which is compatible with the process chemicals be used. Mapco recommends the use of an adhesive backed teflon type gasket.

DRAIN AND SUPPLY PIPING - Follow proper plumbing codes when installing plumbing. Double wall containment may be required. **DO NOT** tap into potable drinking water for supply of clean water. Use the proper back-flow valves, etc. to prevent cross-contamination.

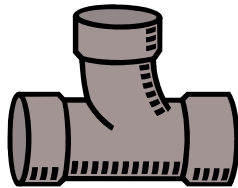

1. The drain is marked with a tag. It is good practice to install a trap and valve on the drain line. **DO NOT** reduce the drain line diameter. Unit could overflow and cause damage.
2. The supply line should be plumbed using sch. 80 PVC or CPVC as a minimum. **DO NOT** reduce the supply line. Reducing supply line could cause higher head pressure and reduced flow. Pipe supports should be installed to insure solid installation.
3. In order to minimize plugging of the spray nozzles, a filtering device should be installed on the supply line. If not installed, the nozzles will eventually become plugged and cause the mesh pads to plug. This could create undue stress on the mesh pads and allow chemical to bypass the system.

bath contamination, effluent from initial pad washdowns should be sent to waste treatment until foamy brown traces of oil disappear.

OPERATION IMPORTANT - The polypropylene mesh pads supplied with this unit may contain residual lubricating oil that is used on the knitting needles during pad construction.

Mapco knows of no instance where these oils presented a problem involving contamination of the plating bath. To avoid any possibility of plating

Inadequate washdown procedures and/ or concentrations of chemicals may considerably shorten the service life of polypropylene mesh pads. Mapco offers a more expensive alternate mesh pad constructed of Kynar™. Kynar™ offers a higher degree of resistance to chromic acid and should significantly increase the life expectancy of the first phase pad. These pads are offered as an option and are not standard equipment. Replacement Kynar™ mesh pads cost run three to five times that of polypropylene.

WASHDOWN SCHEDULE (FREQUENCY AND DURATION)

The mist eliminator is designed with one, two or three stages. The first stage will collect the highest percentage of larger chemical droplets and therefore will require more washdown cycles. The last stage (if so equipped) will require the least amount of washdown cycles.

The first stage in most cases will require a washdown every two to three hours. The duration of the washdown will last from 30 seconds to one minute. This can be determined by visual inspection of the effluent. When the water is clean the washdown duration will be established.

The second stage (if so equipped) will require a washdown every three to four hours. The duration of the washdown could last from 10 seconds to one minute. This can be determined by visual inspection of the effluent. When the water is clean the washdown duration will be established.

Proper washdown of the mesh pad will be indicated when effluent produced from washdown runs clear at the end of the wash cycle. For situations involving very light loadings, it may be possible to decrease washdown frequency or duration or both. A lightly colored effluent will indicate the need for more frequent or longer duration washdown of the mesh pad depending on what you plan to do with the effluent..

NOTE: Use the appropriate safety equipment, clothing and eye protection. Follow manufactures recommended safety procedures for safe handling of all chemicals and other potential hazards.

A. SPRAY NOZZLES

Spray nozzles should be checked for proper spray pattern. The spray pattern should give the appearance of a full cone for each nozzle. If the pattern appears to be erratic, the spray header and nozzle assembly should be removed from the unit and cleaned. Improper or no spray can cause severe plugging and deterioration of the mesh pads. Mapco recommends the use of a strainer in the main header line to minimize nozzle plugging.

1. Shut off water supply to spray header. Follow proper safety procedures to insure against header discharge while working on spray header.
2. Remove bolts securing header flange to side-wall of scrubber. Break apart union connection at main spray header. Take all necessary precautions to avoid spillage of solution. Be sure solution has completely drained from header. Pry header away from backing plate.

Exercise caution to avoid breaking header flange when removing or prying. Remove header from unit.

3. Remove threaded end cap and/or all spray nozzles from spray header. Remove all debris from nozzles and header.
4. Reverse above steps and re-install. Make sure header flange and backing plate are secured and leak proof. Mapco recommends the use of a 100% silicone caulking and /or Teflon gasket.

B. MESH PAD FILTER MEDIA

Mesh pads should be checked for plugging, build-up or separation from retainer. Under normal circumstances, the mesh pad filter media requires minimal maintenance, provided, the spray nozzles, washdown schedule, and washdown concentration are maintained. Other factors that may accelerate plugging are minerals in the washdown liquor such as calcium or small dust particles present in the plant air from grinding operations, etc. Should the unit be operated for periods without water,

or other particles are present in the plant air, the mesh pads will eventually plug and/or deteriorate. If mesh pad becomes plugged, remove and clean immediately. MAPCO recommends at a minimum, bi-annual removal and inspection of the Mist Eliminating components. A decreased exhaust volume may indicate plugging of the mesh pad.

The mesh pad and pad retainer can be immersed in a rinse tank to remove accumulated deposits. Eventual replacement of the mesh pad may be necessary. Typical 1st stage pad life ranges from two to four years with proper wash down. MAPCO recommends a spare mesh pad and retainer assembly be kept on hand.

CAUTION NOTE:

Mapco assumes no responsibility or liability for problems resulting from mesh pad replacement by other. Only qualified persons should replace mesh pads when necessary. It is extremely important that the replacement fit as snug as the original.



TROUBLE SHOOTING

PROBLEM	POSSIBLE CAUSE
POOR SPRAY PATTERN	<ul style="list-style-type: none"> • Spray Nozzles plugged up • Spray Headers plugged up • Pump suction blocked • Pump discharge piping too small • Insufficient water in sump • Pump running backwards • Total head requirement exceeds that of pump
UNIT WILL NOT DRAIN	<ul style="list-style-type: none"> • Drain line to tank is not submerged or trapped • Drain line is not sloped towards tank • Drain line plugged • Drain line too small
MOISTURE AFTER UNIT - Some moisture will be evident with only one mesh pad.	<ul style="list-style-type: none"> • Re-Entrainment due to excessive washdown duration • Gap or void in mist eliminator • Mist Eliminator damaged • Velocity too high through mist eliminator • Droplet size too small • Build-up of chemical on Mist Eliminator
LOW REMOVAL EFFICIENCY	<ul style="list-style-type: none"> • Insufficient or no water to spray nozzles • Mist Eliminator plugged or shifted • Velocity too high or too low • Inlet concentration too high
DETERIORATION OF MESH PAD	<ul style="list-style-type: none"> • No water to spray nozzles • Spray nozzles plugged • Concentrated chemical build-up • Plating bath includes chemicals not compatible with polypropylene
DECREASED EXHAUST VOLUME	<ul style="list-style-type: none"> • Insufficient air make-up in building • Mesh pads are plugged • System static pressure too high • Fan belts loose • Duct dampers are closed or broken
OILY SOLUTION IN PLATING BATH	<ul style="list-style-type: none"> • Residual oils used in manufacture of mesh pads. Run several washdown cycles on each phase until clean.

NOTE: Due to the high efficiency of composite mesh pads, plugging can occur from the following sources:

1. Grinding dust, blasting grit. Airborne dust and dirt.
2. Mineral deposit from water supply.
3. Flux from soldering or welding process.
4. Oil mist from machining operations.

MIST- MASTER™ INLINE MIST ELIMINATOR

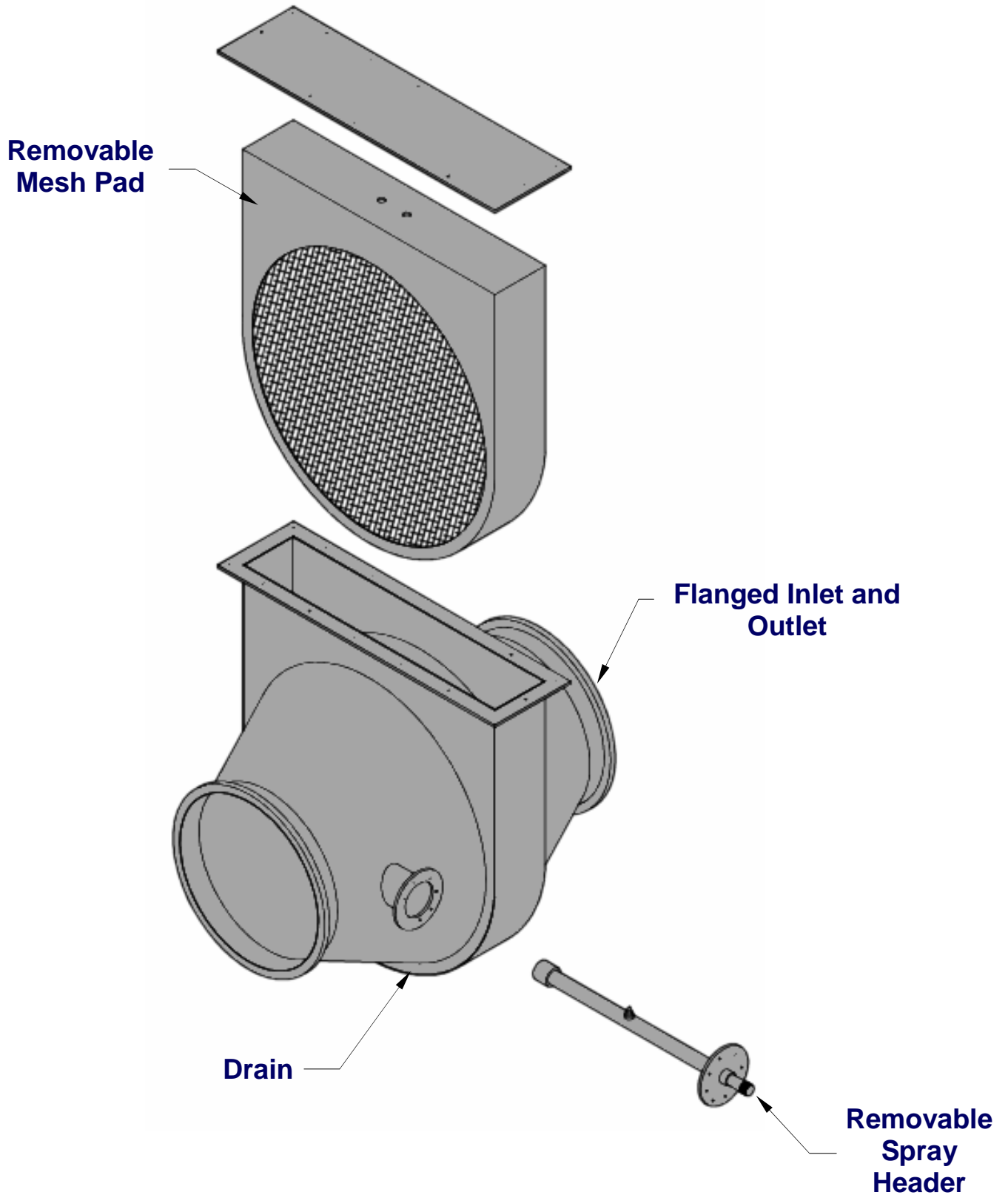

TERMINATOR™ EXHAUST HOOD

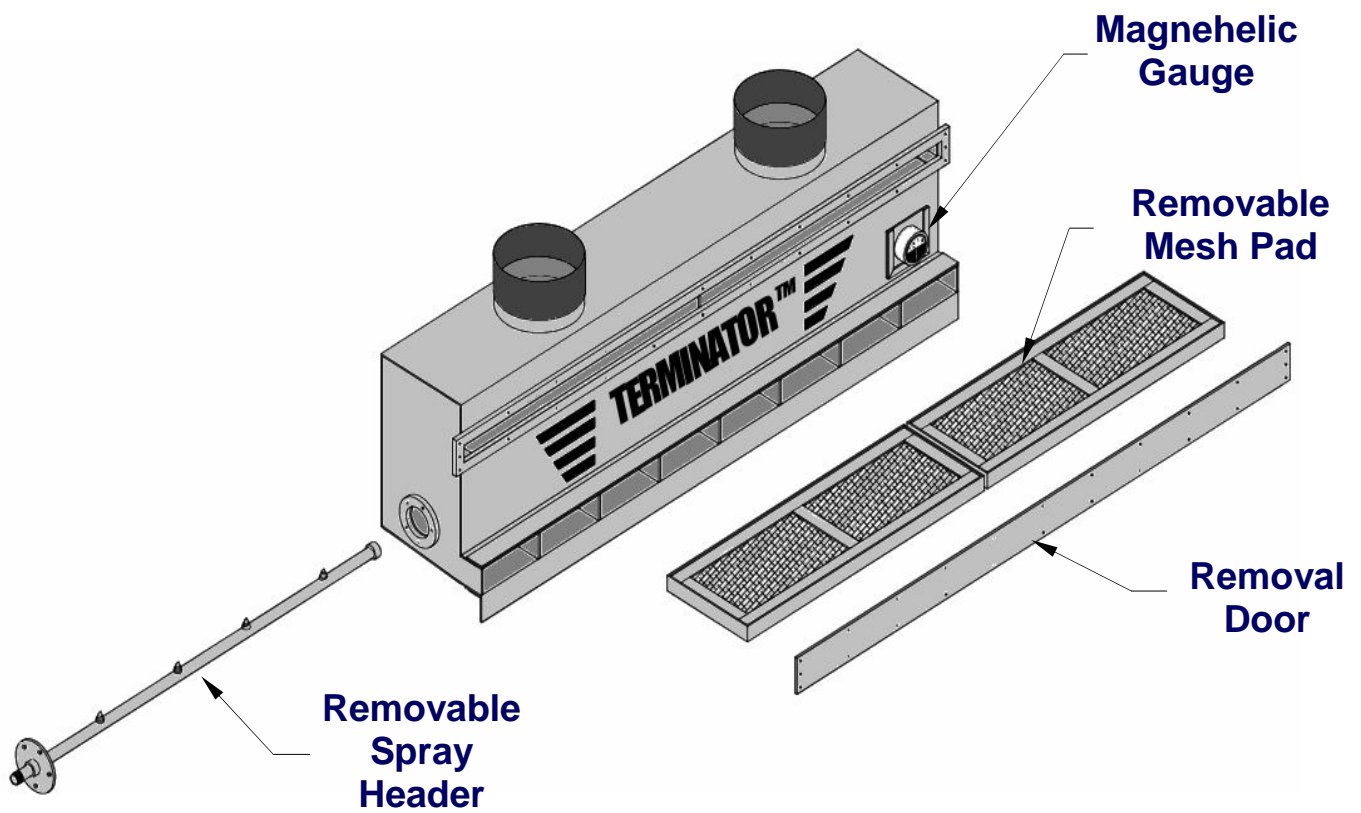

MW-400 HORIZONTAL MIST ELIMINATOR

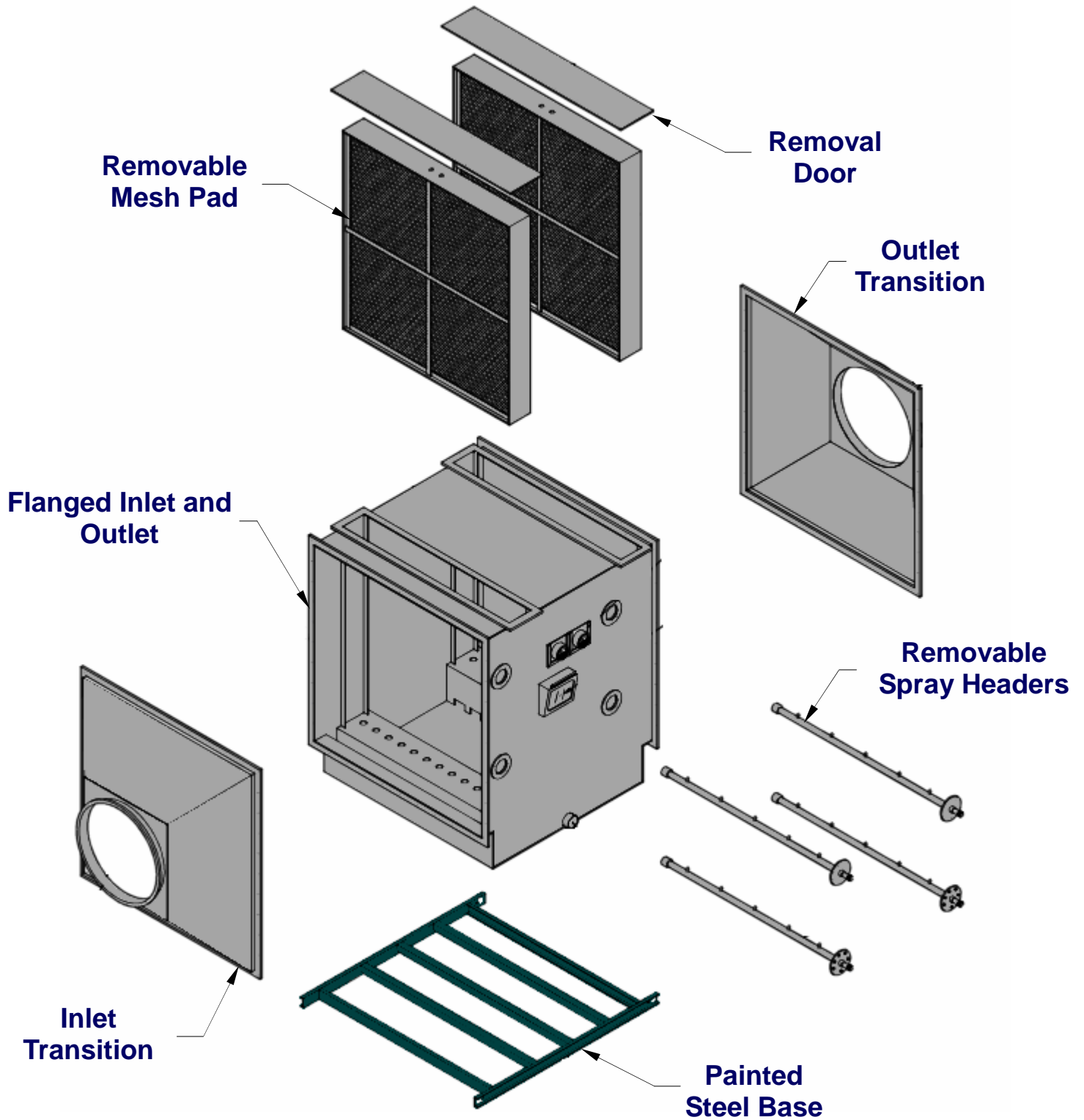

Highest Value
Exhaust and Pollution
Control Equipment

“and the
beat
goes
on”

Corrosion Resistant PVC Duct
Corzan™ Duct
Fiberglass Overlaid Duct



Turnkey
Installations



Corzan™
Duct



Motorized Dampers



Terminator™
Composite Mesh Pad
Exhaust Hoods

