

1-800-214-7716
www.midwestair.com



PVC Ductwork

Tuff Duct™



**N.A.D. NORTH ISLAND
HARD CHROME PLATING**



**COMP X
INTERNATIONAL**

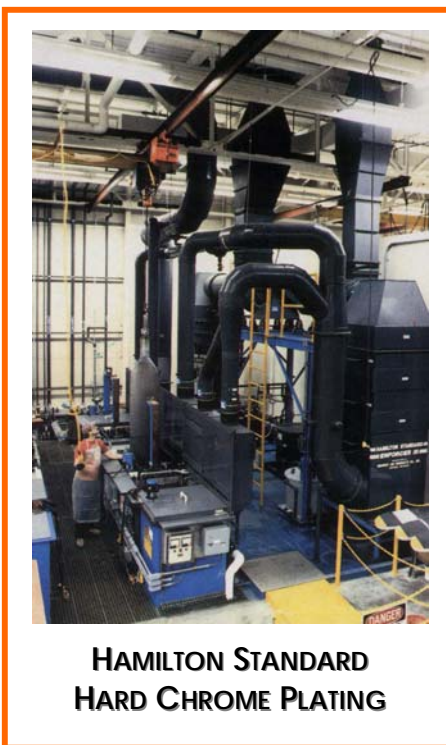

**HAMILTON STANDARD
HARD CHROME PLATING**

- wet scrubbers
- chrome (CMP) scrubbers
- mist eliminators (CMP)
- exhaust fans
- exhaust hoods
- canopy hoods
- ductwork
- installation
- maintenance programs
- custom fabrications
- design services

PO Box 5319
281 Hughes Drive
Traverse City, MI 49686

Ph:231-941-5865
Fax: 231-941-1636



CORZAN™ CPVC DUCT INSTALLATION

Mapco custom-engineered exhaust systems are designed and built by experienced professionals with years of experience in the Metal Finishing Industry. Using only the best materials, all Mapco duct systems utilize type I, grade I, seamless extruded PVC duct up to 24" diameter. All sizes beyond 24" are fabricated from heavy gauge type II, grade I PVC which is the same color as the extruded sizes.

WHY TOTAL RESPONSIBILITY

Efficient and effective exhaust systems are critical to your operations. Fans, fume scrubbers, hoods and ductwork must all be carefully specified, fabricated and installed so you can operate efficiently. Our commitment to quality insures our customers receive the maximum value for their money. Our commitment and ability to solve your problems has made Mapco the innovative leader in the field of Air Pollution Control Technology.

DEGREE OF CONTROL

What degree of control is required? Is the surface area of the tank of prime consideration? Should the design include additional CFM to ventilate parts as they are removed from the tank? Is total control of the fume required? Is a push/pull design practical for your application?

Before CFM volumes can be assigned to the various process tanks, the intent or purpose of the exhaust system has to be defined. Only after you have answered the above questions, can you begin to design a system that will insure a profitable operation and provide a safe environment for your employees.

OSHA Guide 1910, page 20, Section (7), (iv) states "The exhaust system, consisting of hoods, ducts, air mover, and discharge outlet, shall be designed in accordance with American National Standard Fundamentals Governing the Design and Operation of Local Exhaust systems, Z9.1-1991, or the manual, Industrial Ventilation, published by the American Conference of Governmental Industrial Hygienists 2004". These manuals have long been used as the industry standard for designing exhaust system volumes for open surface tanks. In most cases these standards are fine, but no distinction is made between allocation of exhaust volume to vent the tank surface vs venting work in process.

PRINCIPLES FOR CONTROLLING COST

Because there are so many variables to consider when designing an exhaust system, it is not uncommon to see a broad range of CFM volumes from various manufacturers.

The first impact of an exhaust system is the initial cost of the system. A careful evaluation of all cost variables entering into the exhaust system should be made if maximum economy is to be achieved. The designer has a great influence on these costs when specifying the duct system material, total CFM, system operating pressure, duct size and complexity, fan horsepower, control device and space requirements. Determining factors are air quantity and system total pressure. For example, it has been determined that based on 6 cents per Kw/Hr cost of electrical energy, an exhaust system cost 2 cents per cfm, per 1/4 inch static pressure. Therefore, a 1/4 inch rise in static pressure for a 100,000 CFM system would add \$2,000.00 to the cost of operation for a one year period. Some time-proven practices for keeping cost down are:

1. Keep the air quantity to a minimum. This is accomplished by totally enclosing the tank, using a push/pull system or enclosing as much area around the exhaust hood as possible (do not compromise on the exhaust volume to the point where you are under the minimum required control velocity to maintain the specified contaminant evolution for the process involved).
2. Use the minimum number of fittings possible. A short radius elbow for example could have the loss equivalent to 29 feet of straight duct.
3. Use materials that are compatible with the environment.
4. Select a control device that yields the required efficiency at the lowest possible pressure drop.

DESIGN METHODS

The current edition of the Industrial Ventilation Manual offers two basic methods for calculating exhaust volumes for ventilation systems.

METHOD I

Push/pull - A push/pull ventilation system (see fig.1) utilizes a nozzle that pushes a jet of air across the tank surface into an exhaust hood. Effectiveness of the push jet is a function of its momentum which can be related to the product of the nozzle supply air flow and the nozzle exit velocity. The manual offers technical justification for ventilating the surface of a process tank with an exhaust volume of 100 cfm/ ft² of tank surface area for "low activity" processes and 200 cfm/ ft² for higher emission processes.

The exhaust slot or slots should be sized for 2000 fpm to effectively capture the push jet volume as it moves across the tank surface.

Cross draft velocities in excess of 75 ft/min, high temperatures or wide tanks (8 feet or more) may require increased push and/or pull flows. To account for the effects of these variables, a $\pm 20\%$ flow adjustment should be designed into both the push and pull flow systems wherever practical. When ventilation of the processing parts is desired, additional CFM volumes must be allocated to the upper hood slots on upright, multi-slotted hoods. In some cases it is necessary to add a second, elevated push header to direct flow towards the upper slot. Any shielding of the hoods and/or hoist will drastically improve the exhaust hood performance.

Push air header - The push air header should be located as near the tank edge as possible to minimize the height above the liquid level. The push air header should be round so it can be rotated and adjusted during start-up. The nozzle axis can be angled down a maximum of 20° to permit the jet to clear obstructions. Any opening between the nozzle and tank lip should be sealed. For most applications a $1/4"$ diameter hole on $1-1/2"$ to $2"$ centers is sufficient. Usually, 11 to 12 CFM respectively for

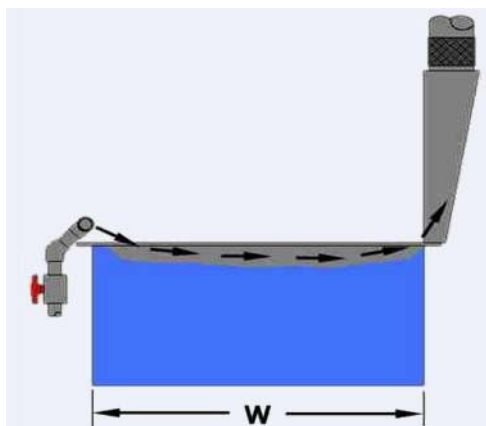

every one foot in length. The push header diameter should be a minimum of 2 to 3 times the area of the nozzle holes to assure even jet flow. Supply lines to push air headers should be equipped with a gate or diaphragm valve for best control. Size the main trunkline for 3,000 to 5,000 FPM velocity. Finally, a high pressure blower should be selected to power the system. Calculate the pressure drop across the system and choose the appropriate blower for the job.

METHOD II

Straight Exhaust - Prior to using 75 CFM/ft² in conjunction with a push/pull system, the most common method of exhaust volume calculation was to use the tables as outlined in the A.C.G.I.H. manual, section 10-102. The table on page (102) can be used for general calculations. For more detailed information, refer to the A.C.G.I.H. manual section 10-103, (Specific Operations).

1. Obtain the recommended control velocity for the specific operation from Table 10.70.3.
2. Determine width to length ratio by dividing width of tank (distance slot has to pull) by length of tank.
3. Select CFM/ ft² based on control velocity and W to L ratio from Table II.
4. Calculate exhaust volume as product of CFM/ ft² X surface area of tank (see Table 10.70.4.).

EXAMPLE

Given: Chrome Plating Tank 6' x 2'-6"
Free standing in room
No cross drafts

- a. Hood (MSL) along 6' side
Hood on free standing tank
W = 2'-6"; L = 6'; W/L = 0.42
Surface area = 6' x 2'-6" = 15 ft²
- b. Process - Chrome Plating Control velocity - 150 fpm (from Table 10.70.3.) Minimum exhaust rate - 250 cfm/ft² (from Table 10.70.4.) Minimum exhaust volume - 15 x 250 = 3,750 cfm.

This method of CFM calculation can also be used in conjunction with a push air system with either a single slot hood or a multi-slotted hood. Depending on the process, the total calculated exhaust volume can be reduced by 20% to 50%. A minimum of 75 cfm/ft² of tank surface area ($\pm 20\%$) should be allocated to the bottom slot with the remainder allocated to the top slot or slots. This will work fine for low production operations with low temperature tanks.

High production operations with high temperature and/or aggressive chemicals should have additional CFM allocated to the top slots for better control of fumes as the parts exit the tank. Shielding between the hoods and/or under the hoist will drastically improve the performance of the exhaust system.

Push air volume should be calculated in the same manner as described under the Push-Pull Ventilation section on page 10-113 in the 25th edition of the A.C.G.I.H. manual .

NOTES:

The effective width (W) over which a hood must pull air to operate is critical to its performance. If the hood face is set back from the tank lip, include this set back in measuring tank width. It is not practical to ventilate across the long dimension of a tank if the $W \div L$ exceeds 2.0. It is undesirable to do so when $W \div L$ exceeds 1.0.

- a. If W= 20 to 30 inches, a hood on one side is suitable
- b. If W= 31 to 36 inches, a hood on both sides is desirable (ref. push/pull design).
- c. If W= 36 to 48 inches, a hood on both sides is necessary unless all conditions are optimum (ref. push/pull design).

- d. If W= 48 inches or greater, local exhaust is not practical. A push air system or enclosure should be considered.
- e. Duct velocity = 2,000 to 3,400 fpm
- f. Maximum hood plenum velocity = 2,000 fpm
- g. Entry loss = 1.78 VP plus duct entry loss
- h. Maximum hood slot velocity = 3,000 fpm
- i. Hood lengths 6 ft. or greater, multiple take-offs are desirable. Hood lengths 10 ft. or greater, multiple take-offs are necessary.

Table I Minimum Control Velocity (fpm)

OPERATION	PROCESS	CONTROL VELOCITY	CONTROL DEVICE RECOMMENDED	OPERATION	PROCESS	CONTROL VELOCITY	CONTROL DEVICE RECOMMENDED	
PLATING	Cadmium	50	[note 1]	CLEANING (not boiling)	Caustic	75	[note 1]	
	Chrome	150	Yes		Electrolytic	75	[note 1]	
	Copper	75	Yes		CLEANING (boiling)	Caustic	100	[note 1]
	Tin	75	[note 1]			Electrolytic	100	[note 1]
	Zinc	75	[note 1]		BRIGHT DIP	Aluminum	150	Yes [note 2]
ANODIZING	Sulfuric	100	Yes	Copper	150	Yes [note 2]		
	Chromic	100	Yes	Brass	150	Yes [note 2]		
PICKLING	Nitric	150	Yes [note 2]	STRIPPING	Nitric	150	Yes [note 2]	
	Sulfuric	100	Yes		Sodium Hydroxide	75	Yes	
	Hydrochloric	150	Yes [note 2]	HOT WATER	Sulfuric	75	Yes	
Nitric/HF	150	Yes [note 2]	Not boiling		50			
				Boiling	75			

- NOTES: 1. In most cases a scrubber is not required [Mapco recommends the installation of a mist eliminator to prevent damage to building, cars and surrounding structures].
 2. Additional control should be considered due to the violent reaction of some processes.

Required Minimum Control Velocity (FPM)	CFM/ft ² to maintain minimum control velocities at following ratios $\frac{\text{tank width (W)}}{\text{tank length (L)}}$				
	0.0 — 0.09	0.1 — 0.24	0.25 — 0.49	0.5 — 0.99	1.0 — 2.0

Hood along one side or two parallel sides of tank when tank is against a wall or shielded. Also for manifold along tank centerline.

50	50	60	75	90	100
75	75	90	110	130	150
100	100	125	150	175	200
150	150	190	225	250	250

Hood along one side or two parallel sides of free standing tank.

50	75	90	100	110	125
75	110	130	150	170	190
100	150	175	200	225	250
150	225	250	250	250	250

- Notes: 1. Use W/2 as tank width in computing W/L for hood along centerline or two parallel sides of tank.
 2. If hood face is set back from tank, distance should be included in tank width dimension.

FUME HOOD DESIGN

When the intended purpose of the process exhaust has been established, the proper exhaust hood can be selected.

Lip exhaust, single-slot hoods are ideal for ventilating the process tank surface. This design will do little or nothing for capture of fumes evolving from parts as they move above the capture range of the exhaust slot. Lip exhaust hoods work well with a push system as long as the slot, or slots are sized for 2000 fpm and obstructions are kept to a minimum. When a push-pull system is not practical, lip exhaust on opposing sides of the tank may be the best alternative. Keep in mind that the effective range of each slot is approximately 30". Beyond this point, capture velocity drops off significantly.

Upright, multi-slotted hoods are required when parts are to be ventilated. If the system design requires a push system, the lowest slot on the hood will be assigned the function of ventilating the tank surface with the help of the push jet. Upper slots will require additional CFM volume for the express purpose of ventilating parts. The height of the top slot is usually determined by the depth of the tank or height of the parts when they have cleared the tank. Processing of large parts or barrel lines usually require an elevated slot to vent the parts or barrel. A second, elevated push header will increase the efficiency of the exhaust when this is the case. Control of process fumes becomes increasingly more difficult as the fumes rise higher above the tank surface. Cross drafts created by negative pressure in the building or drafts created by hoist and part movement make it nearly impossible to capture all of the fumes.

Canopy hoods are not practical on open-surface process tanks unless two or three sides can be shielded or enclosed. In most cases the required CFM volume for this arrangement is greater than other hood designs. In any case, the quantity of air in cubic feet per minute necessary to be exhausted through an enclosing hood shall not be less than the product of the control velocity times the net area of all openings in the enclosure through which air can flow.

Specialized designs exist for low-volume capture of surface fumes that enlist the aid of manual, automatic or permanent tank covers. Practical tank cover designs (or design limitations) are usually dictated by the specific process and the type of material transfer system used. Low-volume, efficient capture of fumes, arising from parts can be achieved with a ventilated workload enclosure or traveling canopy hood with side shields.

Design parameters for these types of systems are too complicated or operation-specific to be covered in this manual.

DUCT DESIGN

Mapco air pollution control systems are typically designed in accordance with the recommended standards of **ACGIH, ANSI, SPI, OSHA** and **SMACNA**. Depending on the process, we may choose to use values higher than those recommended in the above manuals.

System components recommended by Mapco include; clean out doors on main trunklines, drain traps, isolation of the fan inlet and outlet, spring isolators, stack support independent of the fan, dampers with seals, teflon gaskets, stainless steel hardware, 360° stainless steel split hangers with 3/8" diameter stainless steel rod, flexible hood outlet connections, flanged connections at equipment, clean out doors on all exhaust hoods and reinforcement according to **SMACNA** recommendations for thermoplastic ductwork.

STANDARD SPECIFICATIONS FOR RIGID POLYVINYL CHLORIDE DUCT

All ductwork is fabricated in accordance with the Sheet Metal and Air Conditioning Contractors National Association (**SMACNA**), a manual on Thermoplastic Construction when possible. All ductwork to be fabricated from Type II Grade I, Type I, Grade I and extruded Type I grade I PVC. Type II, grade I PVC conforms to ASTM D 1784-81, Class 15333-D and or Class 16444-D, ASTM E 84 Flame Spread Rate 15, UL 94 VO Standards and Federal Specification L-P 535e. Type I, Grade I PVC conforms to ASTM D 1784-81, Class 12454, ASTM E 84 Flame Spread Rate 15, UL 94 VO, 5V Flammability Rating and Federal Specification LP 535e. Maximum (air stream) application temperature is 140° F.

DUCT CONSTRUCTION-POLYVINYL CHLORIDE

Round Duct Diameter (inches)	Wall Thickness (inches)
4" to 24"	3/16" extruded
25" to 48"	3/16"
49" and up	1/4"

Round ductwork fabricated of Type I, Grade I shall be hot rolled and stress relieved. Round ductwork fabricated of Type II, Grade I shall be cold rolled with longitudinal seams butt welded. Elbows (60° and 90°) shall be (5) gore pieced proportionately. Elbows (30° and 45°) shall be (3) gore pieced proportionately. Molded or formed elbows with 1-1/2 centerline radius will be acceptable.

Elbows to be welded inside and out with (3) passes outside and (1) pass inside. Smaller diameter elbows to be tack welded inside with (3) passes outside. When conforming to **SMACNA** specifications material thickness will vary depending on pressure drop through duct and method of reinforcement.

Transition pieces in mains and sub-mains shall be tapered. Angular limitations for transitions shall be no greater than 20° for diverging flow and no greater than 30° for contracting flow where field conditions permit.

Branches or tees shall enter the main at the large end of the transition and at an angle not exceeding 45° wherever possible. Minimum wall thickness and reinforcement shall be that required for the larger diameter.

Branches shall not be positioned directly opposite one another on a main or sub-main.

Rectangular Ductwork

Max. Duct Dimensions	Wall Thickness
up to 22"	3/16"
23" and up	1/4"

Straight duct sections shall have formed corner construction for maximum strength. Welded corners will not be acceptable. Transitions and tapers shall have formed corners wherever practical.

Rectangular elbows shall be fabricated from flat stock with welded corner construction and shall be fabricated with a center line radius equal to at least 1-1/2 times the dimension of the elbow side wherever conditions permit.

FLANGES, GASKETS AND DUCT CONNECTIONS

Flanges may be thermal formed from type I or type II, extruded PVC angle or fabricated from flat rigid PVC sheet and welded to the duct sections. Flanges shall be continuously back welded with (3) passes. Flange face shall be continuously welded and smooth. Unless otherwise specified, the bolt size and spacing of bolt holes shall be in accordance with Table III. Bolts, nuts, flat and lock washers shall be stainless steel. Flat washers shall be placed under the bolt head and nut.

Gasket material shall be 100% silicone caulk and shall be of sufficient quantity to properly seal the joint.

HANGERS AND SUPPORTS

All horizontal duct shall be supported as specified in Table IV. Duct shall be supported independently of hoods, fans, stacks or other equipment and on both sides of an expansion or flexible joint. In locations where hangers are exposed to corrosive atmosphere adjacent to hoods, tanks or other process equipment, hanger material shall be stainless steel or epoxy coated mild steel. All bolts, nuts, washers and other attaching hardware shall be fabricated from stainless steel.

Hangers and supports shall be securely fastened to the building structure wherever possible. In locations where this is not possible, supports shall be bolted to concrete floor. Care shall be taken to install hangers so as to avoid creating conditions of stress in the finished installation.

WELDING

Welding shall be done by the hot gas fusion welding method utilizing PVC filler rod as manufactured for this purpose. Welding shall be performed by workmen adequately trained in the art of PVC welding. Ductwork and similar air passage enclosures must be finished, completely air and water tight with smooth interior surfaces. Ductwork shall be completely free from cracks, distortions or other imperfections.

LONGITUDINAL SEAMS

Longitudinal seams shall be butt welded utilizing an automatic butt welding machine. Alignment of longitudinal seams in adjacent butt welded sections shall be avoided, and the seams shall be staggered. When joining sections together a minimum of (3) passes outside and (1) pass inside is standard.

FLEXIBLE CONNECTIONS

Flexible connections shall be furnished and installed to form an anti-vibration barrier at equipment locations and expansion joints where indicated on the drawings. Flexible connections shall be fabricated from flexible plasticized PVC using material not less than 1/8 inch thick. Support or hanger shall be provided at each end of the flexible connection in a horizontal position.

DRAIN TRAPS

Drain traps shall be installed at low points in main trunkline. Trap shall be a minimum of 3" wide and designed to allow condensation in the ductwork to overflow into tapered box with 1-1/2" diameter threaded PVC coupling. A PVC coupling welded to the bottom of the duct is not acceptable.

CLEAN OUT DOORS

Clean out or inspection doors shall be installed on the main trunkline, sub-mains, hoods, fan and scrubber. Doors shall be heat formed to fit the circumference of round duct or Tee type connection.

Clean out doors shall be a minimum of 3/8" thick PVC bolted to a 1" x 3/8" thick PVC frame. Frame shall be welded to duct with (3) passes outside and (1) pass inside.

Door shall be bolted to frame with stainless steel hex head bolts. Frame work shall be drilled and tapped to accept bolts. Threads shall be capable of handling a minimum of 15 foot lbs. torque.

Clean out door width and length shall be a minimum of 1/4 the diameter of the duct it is installed on, or 8" x 8" whichever is larger.

TABLE III FLANGE SIZE/ BOLT SIZE/ BOLT SPACING

DUCT DIAMETER OR WIDTH	ANGLE FLANGE	FLAT FLANGE	BOLT SIZE inches	BOLT HOLE DIAMETER inches	BOLT SPACING	
					Round	Rectangular
					No. of Equally Spaced Bolts	Max Center to Center Spacing
6 8 10 12 14 16 18 20 22 24	1-1/2 x 1-1/2 x 3/16	1-1/2 x 3/8	1/4	5/16	6	4
					8	4
					8	4
					12	4
					12	4
					16	4
					16	4
					16	4
					20	4
					20	4
26 28 30 36 42 48 Above 48	2 x 2 x 1/4	2 x 3/8	5/16	3/8	24	4
					24	4
					24	4
					32	4
					36	4
					40	4
					-	4

TABLE IV ROUND DUCT

DUCT DIAMETER	MINIMUM HANGER MATERIAL	ROD DIAMETER	MAXIMUM CENTER SPACING
18 and below	1-1/4" X 1/8"	3/8"	8'-0"
19 thru 32	1-1/2" X 3/16"	3/8"	8'-0"
33 and above	2" X 3/16"	3/8"	8'-0"

RECTANGULAR DUCT

DUCT WIDTH	MINIMUM SIZE OF ANGLE MATERIAL	ROD DIAMETER	MAXIMUM CENTER SPACING
18 and below	1" X 1" X 1/8"	3/8"	8'-0"
19 thru 54	1-1/2" X 1-1/2" X 1/8"	3/8"	8'-0"
55 thru 84	2" X 2" X 1/8"	3/8"	8'-0"
85 and above	2" X 2" X 1/8"	3/8"	5'-0"

DUCT FITTINGS

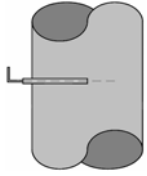

Blastgate Damper

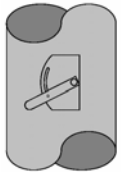

Butterfly Locking Damper

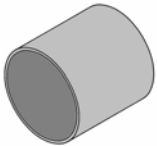

Round Duct

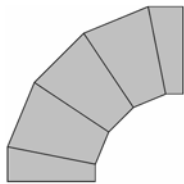

Elbows

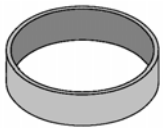

Couplings

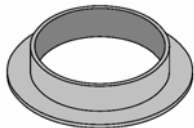

Flanges

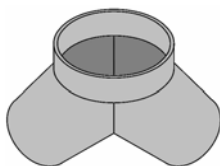

Pants

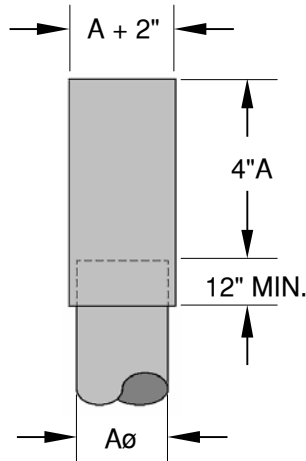

No - Loss Stack

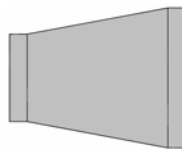

Taper

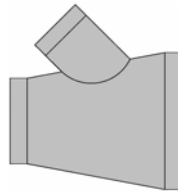

Taper With Lateral

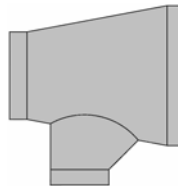

Taper With Boot

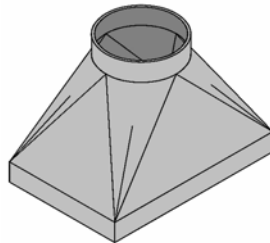

Square to Round
Transitions

Stack Cap With
Back Draft Damper

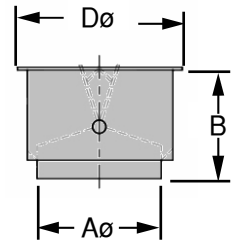
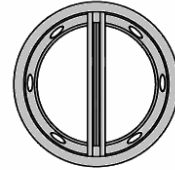
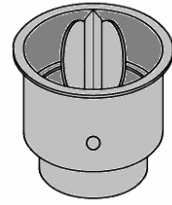

A	B	D
6-5/8	16	12-3/4
8-5/8	16	14
9-3/8	18	14
10-3/4	18	16
12-3/4	20	18
14	20	20
16	20	22
18	22	24
20	22	26
24	24	30
26-3/16	26	32
28-3/16	26	34
30-3/16	28	36
32-3/16	28	38
34-3/16	30	40
36-3/16	30	44
38-3/16	32	46
40-3/16	32	48
42-3/16	34	50
44-3/16	34	52
46-3/16	36	54
48-3/16	38	56
50-1/4	38	58
52-1/4	38	60
54-1/4	40	62
56-1/4	40	64
58-1/4	42	66
60-1/4	42	68
62-1/4	44	70
64-1/4	44	72
68-1/4	46	74

EXHAUST HOODS

All hoods shown on this page are standard hood designs used frequently in the Metal Finishing Industry. Mapco can design virtually any type of hood to fit your process. All hoods are fabricated of corrosion-resistant materials including PVC, CPVC,

polypropylene, stainless steel and FRP. Most of these fume hood designs can be used in conjunction with a push-air system to aid in fume removal and / or CFM volume minimization.

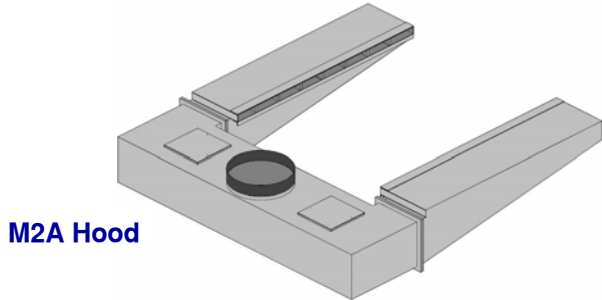

M2A Hood

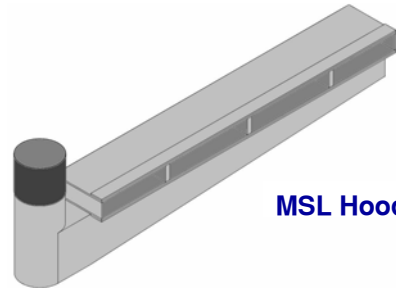

MSL Hood

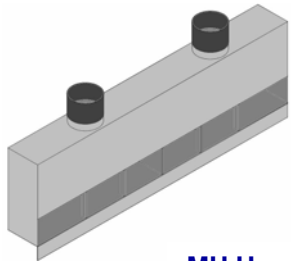

MU Hood

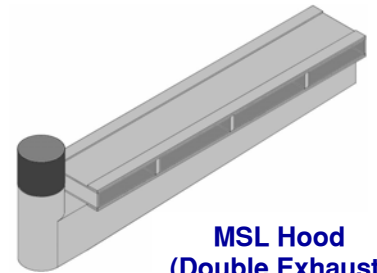

MSL Hood (Double Exhaust)

HOOD	APPLICATION
M2A	Low profile opposed lateral design with end take-off.
MSL	Low profile with end take-off.
MDL MLH MLH (down-draft)	Low profile with center take-off for vertical up-draft or down-draft duct systems. Typically used on automatic or manual lines when clearance is a problem.
MU3	High profile hood used for venting tank surface and some fumes off parts as they exit tank.
MU	Large slot for excessive fuming at tank.
MM	Low profile used when fuming off part is not excessive.

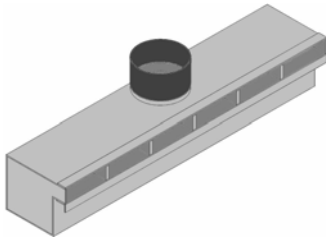

MLH Hood

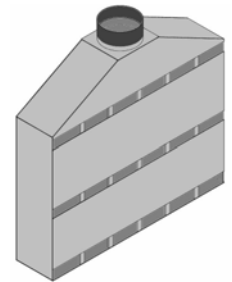

MU3 Hood

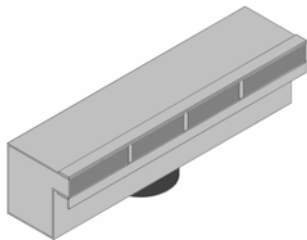

MLH Hood (Down Draft)

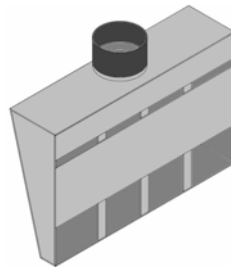

MM Hood

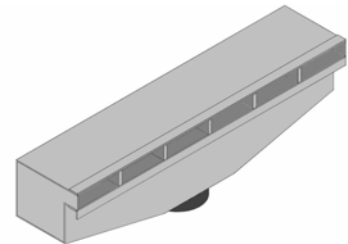

MDL Hood (Down Draft)

STANDARD FEATURES

- Flexible outlet connections
- Drains at low points
- Internal reinforcing
- Heavy gauge material
- Drip lips

OPTIONAL FEATURES

- Removable shields
- Adjustable baffles
- 3/8" clean out doors
- Removable mesh pads
- Removable spray headers

Highest Value
Exhaust and Pollution
Control Equipment

“and the
beat
goes
on”

Corrosion Resistant PVC Duct
Corzan™ Duct
Fiberglass Overlaid Duct



Turnkey
Installations



Corzan™
Duct



Motorized Dampers



Terminator™
Composite Mesh Pad
Exhaust Hoods

