

1-800-214-7716  
www.midwestair.com

**M A P C O**  
MIDWEST AIR PRODUCTS CO., INC.

## PVC Exhaust Hoods



**N.A.D. NORTH ISLAND  
HARD CHROME PLATING**

- wet scrubbers
- chrome (CMP) scrubbers
- mist eliminators (CMP)
- exhaust fans
- exhaust hoods
- canopy hoods
- ductwork
- installation
- maintenance programs
- custom fabrications
- design services



**HAMILTON STANDARD  
HARD CHROME PLATING**



**COMP X  
INTERNATIONAL**



**CORZAN™ CPVC DUCT INSTALLATION**

PO Box 5319  
281 Hughes Drive  
Traverse City, MI 49686

Ph: 231-941-5865  
Fax: 231-941-1636

## FUME HOOD DESIGN

When the intended purpose of the process exhaust has been established, the proper exhaust hood can be selected.

Lip exhaust, single-slot hoods are ideal for ventilating the process tank surface. This design will do little or nothing for capture of fumes evolving from parts as they move above the capture range of the exhaust slot. Lip exhaust hoods work well with a push system as long as the slot, or slots are sized for 2000 fpm and obstructions are kept to a minimum. When a push-pull system is not practical, lip exhaust on opposing sides of the tank may be the best alternative. Keep in mind that the effective range of each slot is approximately 30". Beyond this point, capture velocity drops off significantly.

Upright, multi-slotted hoods are required when parts are to be ventilated. If the system design requires a push system, the lowest slot on the hood will be assigned the function of ventilating the tank surface with the help of the push jet. Upper slots will require additional CFM volume for the express purpose of ventilating parts. The height of the top slot is usually determined by the depth of the tank or height of the parts when they have cleared the tank. Processing of large parts or barrel lines usually require an elevated slot to vent the parts or barrel. A second, elevated push header will increase the efficiency of the exhaust when this is the case. Control of process fumes becomes increasingly more difficult as the fumes rise higher above the tank surface. Cross drafts created by negative pressure in the building or drafts created by hoist and part movement make it nearly impossible to capture all of the fumes.

Canopy hoods are not practical on open-surface process tanks unless two or three sides can be shielded or enclosed. In most cases the required CFM volume for this arrangement is greater than other hood designs. In any case, the quantity of air in cubic feet per minute necessary to be exhausted through an enclosing hood shall not be less than the product of the control velocity times the net area of all openings in the enclosure through which air can flow.

Specialized designs exist for low-volume capture of surface fumes that enlist the aid of manual, automatic or permanent tank covers. Practical tank cover designs (or design limitations) are usually dictated by the specific process and the type of material transfer system used. Low-volume, efficient capture of fumes, arising from parts can be achieved with a ventilated workload enclosure or traveling canopy hood with side shields.

Design parameters for these types of systems are too complicated or operation-specific to be covered in this manual.

Cross draft velocities in excess of 75 ft/min, high temperatures or wide tanks (8 feet or more) may require increased push and/or pull flows. To account for the effects of these variables, a  $\pm 20\%$  flow adjustment should be designed into both the push and pull flow systems wherever practical. When ventilation of the processing parts is desired, additional CFM volumes must be allocated to the upper hood slots on upright, multi-slotted hoods. In some cases it is necessary to add a second, elevated push header to direct flow towards the upper slot. Any shielding of the hoods and/or hoist will drastically improve the exhaust hood performance.

**Push air header** - The push air header should be located as near the tank edge as possible to minimize the height above the liquid level. The push air header should be round so it can be rotated and adjusted during start-up. The nozzle axis can be angled down a maximum of  $20^\circ$  to permit the jet to clear obstructions. Any opening between the nozzle and tank lip should be sealed. For most applications a 1/4" diameter hole on 1-1/2" to 2" centers is sufficient. Usually, 11 to 12 CFM respectively for

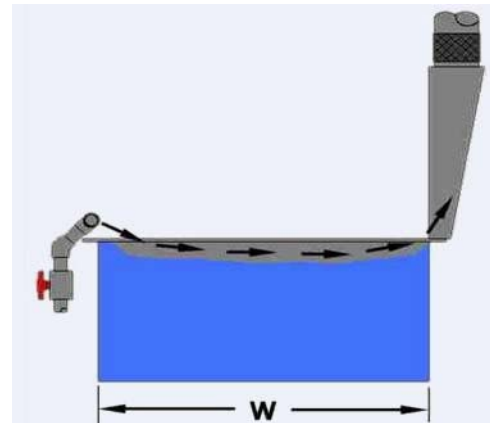

every one foot in length. The push header diameter should be a minimum of 2 to 3 times the area of the nozzle holes to assure even jet flow. Supply lines to push air headers should be equipped with a gate or diaphragm valve for best control. Size the main trunkline for 3,000 to 5,000 FPM velocity. Finally, a high pressure blower should be selected to power the system. Calculate the pressure drop across the system and choose the appropriate blower for the job.

**EXHAUST HOODS**

All hoods shown on this page are standard hood designs used frequently in the Metal Finishing Industry. Mapco can design virtually any type of hood to fit your process. All hoods are fabricated of corrosion-resistant materials including PVC, CPVC,

polypropylene, stainless steel and FRP. Most of these fume hood designs can be used in conjunction with a push-air system to aid in fume removal and / or CFM volume minimization.

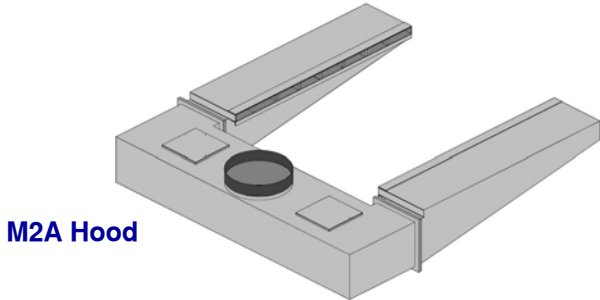

**M2A Hood**

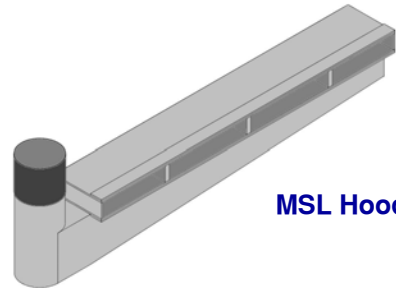

**MSL Hood**

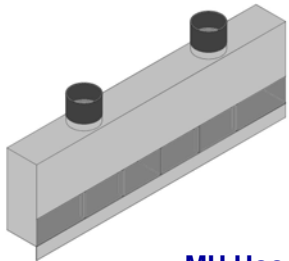

**MU Hood**

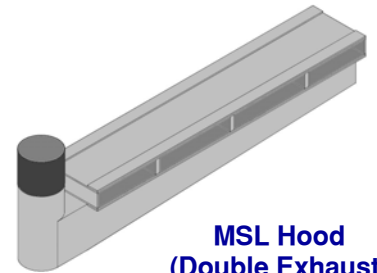

**MSL Hood (Double Exhaust)**

HOOD	APPLICATION
M2A	Low profile opposed lateral design with end take-off.
MSL	Low profile with end take-off.
MDL MLH MLH (down-draft)	Low profile with center take-off for vertical up-draft or down-draft duct systems. Typically used on automatic or manual lines when clearance is a problem.
MU3	High profile hood used for venting tank surface and some fumes off parts as they exit tank.
MU	Large slot for excessive fuming at tank.
MM	Low profile used when fuming off part is not excessive.

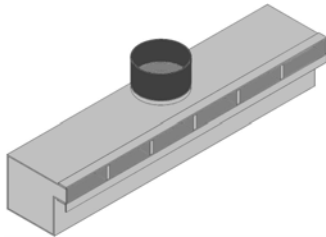

**MLH Hood**

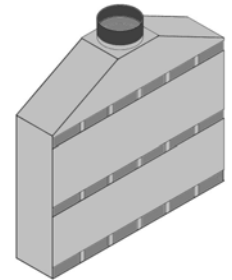

**MU3 Hood**

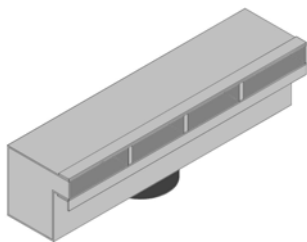

**MLH Hood (Down Draft)**

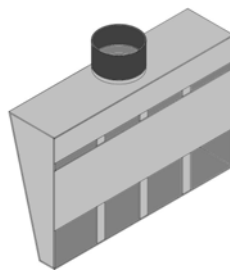

**MM Hood**

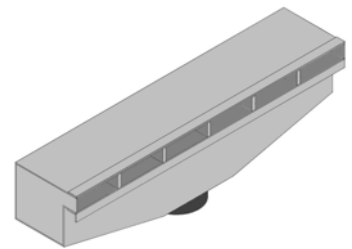

**MDL Hood (Down Draft)**

**STANDARD FEATURES**

- Flexible outlet connections
- Drains at low points
- Internal reinforcing
- Heavy gauge material
- Drip lips

**OPTIONAL FEATURES**

- Removable shields
- Adjustable baffles
- 3/8" clean out doors
- Removable mesh pads
- Removable spray headers

# Highest Value Exhaust and Pollution Control Equipment

“and the  
beat  
goes  
on”

## Corrosion Resistant PVC Duct Corzan™ Duct



Turnkey  
Installations

Corzan™  
Duct



Motorized Dampers



Terminator™  
Composite Mesh Pad  
Exhaust Hoods

